



VOLTAGE OUTPUT CURRENT SENSOR SERIES

Installation & Operation Instructions

Phone: 1-888-967-5224
Website: workaci.com

PRECAUTIONS

- This product is not intended to be used for Life or Safety applications.
- This product is not intended for use in any hazardous or classified locations.
- The A/CTE2, A/CTV2, A/SCTE2 and A/SCTV2 Series Current Sensors must be used on Insulated Conductors Only.

HIGH VOLTAGE

- Disconnect and lock out all power sources before installation as severe injury or death may result from electrical shock due to contact with high voltage wires.

GENERAL INFORMATION

The Voltage Output Analog Current Sensors are designed for use in any AC current monitoring application in which you are looking to monitor a particular piece of equipment for proper operation. All voltage output current sensors use an "Average" current measuring method and should be used in applications where a pure Sinusoidal AC waveform that has very little or no distortion/noise on the conductor being monitored. Applications may include monitoring a resistive type load such as an incandescent light bulb or heating element as well as any single speed linear load. Voltage Output current sensors are available in both solid and split-core versions which also includes a Patented 35 mm Din Rail mounting foot for easy installation in panel mount applications. The solid-core versions are a great choice for new installations or OEM applications in which cost sensitivity, lower trip points and environmental issues like dust and moisture may be of concern. The split-core version of the current sensors work great in retrofit applications and

for use on service technicians vehicles since one or two parts will work in most applications and can be easily installed without disconnecting any wires. For best results, the voltage output current sensors should not be used in applications with switching power supplies or variable speed drives due to the limited operating frequency range. In applications where variable speed drives or waveforms include distortion/noise, ACI recommends the use of the A/CTA2-RMS or A/SCTA2-RMS Series sensors where you need to supply 24 VDC power to the current sensors with a 4-20 mA signal. A 249 Ohm or 499 Ohm 1 Watt resistor can be used to convert the 4-20 mA signal into a useable 1-5 or 2-10 VDC output signal at your building management system or PLC.

FIGURE 1: DIMENSIONS

Solid-Core

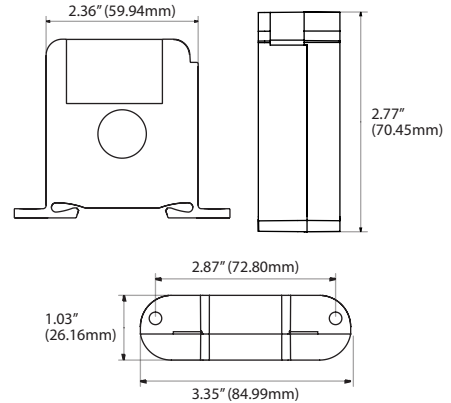

Split-Core

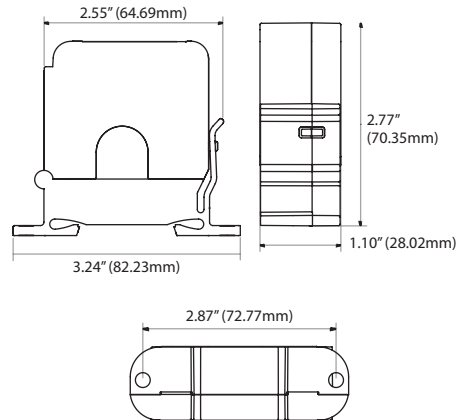

INSTALLATION

Make sure that all installations are in compliance with all national and local electrical codes. Only qualified individuals that are familiar with codes, standards, and proper safety procedures for high-voltage installations should attempt installation. The current sensor will not require external power, since the power for the current sensor is induced from the conductor being monitored.

The current sensor may be mounted in any position using the two #8 x 3/4" Tek screws and the mounting holes in the base, or snapped directly on to the 35mm DIN rail (See **Figure 3**). Leave a minimum distance of 1" (3 cm) between the current sensor and any other magnetic devices such as contactors and transformers.

Latch Operation for A/SCTE2 and A/SCTV2 Series

Press down on the side tab and swing the top of the unit up to open the split core current sensor as shown in **Figure 2**. Press down firmly on the cover to close the current sensor. An audible "click" will be heard as the tab slides over the tongue on the base.

CAUTION: Mating surfaces of the magnetic core are exposed when the sensor is open. Electrical contact grease, present on the cores to prevent corrosion, can capture grit and dirt if care is not exercised. Operation can be impaired if anything prevents good contact between pole pieces. Visually check the mating parts of the core before closing the current sensor.

Current Sensor Setup

The amperage range selected represents the maximum current that can be applied to the conductor being monitored, Do not exceed! All current sensors with selectable ranges will have the range selection jumper factory set on the high range. For models with field selectable amperage ranges, select the correct amperage range using the range selection jumper.

Note: An extra jumper shunt is included. It can be discarded if not needed.

Note: In applications where high vibrations are encountered, ACI recommends to use the jumper shunt without tab. A pliers can help with jumper shunt installation onto the pins.

FIGURE 3: DIN RAIL INSTALLATION

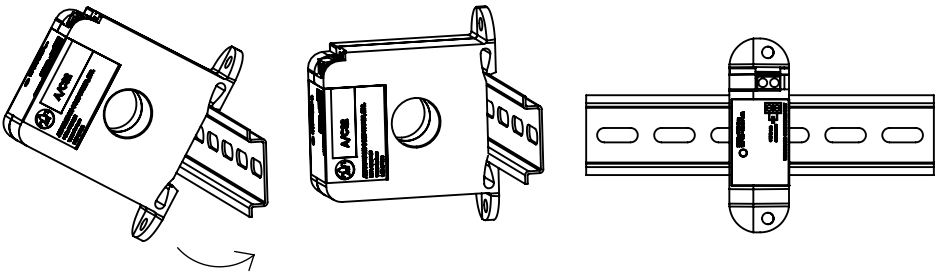

FIGURE 2: OPENING A/SCTV2-50 SERIES

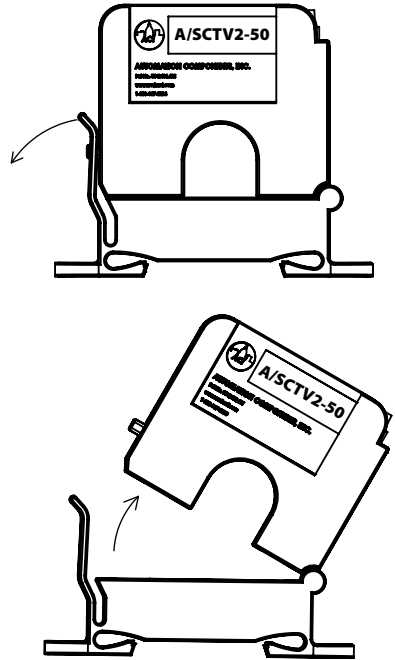
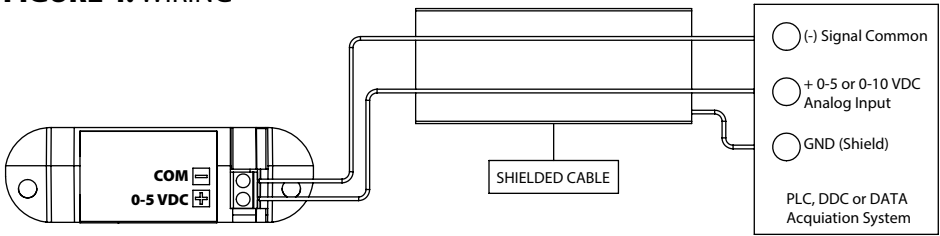

FIGURE 4: WIRING



WIRING INSTRUCTIONS

ACI recommends the use of a two conductor 16 to 22 AWG shielded cable, copper wire only, for all Analog current sensor installations. A maximum wire length of less than 30 meters (98.4 feet) should be used between the current sensors and the Building Management System or controller. All wiring must comply with all local and National Electric Codes.

Note: When using a shielded cable, be sure to connect only (1) end of the shield to ground at the controller. Connecting both ends of the shield to ground may cause a ground loop.

When removing the shield from the sensor end, make sure to properly trim the shield to prevent any chance of shorting. The current sensor terminals are polarity sensitive and represent a linear 0 to 5 or 0 to 10 VDC output signal. Tighten the screws at the terminal block connections to the recommended torque of 0.5 to 0.6 Nm (4.43 to 5.31 in-lbs.). The aperture (hole) size of the current sensor is 0.75" (1.90 cm).

TROUBLESHOOTING

PROBLEM	SOLUTION(S)
No reading	<ul style="list-style-type: none"> - Verify that there is current flowing through the conductor being monitored with a clamp-on current probe. The power for the current sensor is induced from the conductor being monitored. - Check the polarity of the circuit. - Verify that the terminals are screwed down, wires are firmly in place. - Disconnect the wires from the current sensor output. Measure the voltage across the current sensor output with a Voltmeter to verify that the sensor is working properly.
Erratic readings	<ul style="list-style-type: none"> - Verify that the wires are terminated properly. - In areas of high RF interference, shielded cable may be necessary to stabilize signal.
Inaccurate readings	<ul style="list-style-type: none"> - If you suspect that the current sensor is not reading within the accuracy specifications, please contact the factory for assistance.
Current Sensor is operating at a low-level current or failing to operate within the accuracy specifications.	<ul style="list-style-type: none"> - Visually check the mating parts of the core to ensure there is no debris between the split contacts. See Figure 2. - Remove all debris or dust manually and close the current sensor. - Continue to retest the sensor in your application.

STANDARD ORDERING

Model #	Item #	Selectable Ranges	Measurement	AC Waveform	Solid-Core	Split-Core	Output Signal
A/CTE2-50	142389	0 to 10/20/50A	Average	Pure Sinusoidal	•		0 to 5 VDC
A/CTE2-150	142388	0 to 50/100/150A	Average	Pure Sinusoidal	•		0 to 5 VDC
A/SCTE2-50	142385	0 to 10/20/50A	Average	Pure Sinusoidal		•	0 to 5 VDC
A/SCTE2-150	142384	0 to 50/100/150A	Average	Pure Sinusoidal		•	0 to 5 VDC
A/SCTE2-250	142383	0 to 100/200/250A	Average	Pure Sinusoidal		•	0 to 5 VDC
A/CTV2-50	142387	0 to 10/20/50A	Average	Pure Sinusoidal	•		0 to 10 VDC
A/CTV2-150	142386	0 to 50/100/150A	Average	Pure Sinusoidal	•		0 to 10 VDC
A/SCTV2-50	142382	0 to 10/20/50A	Average	Pure Sinusoidal		•	0 to 10 VDC
A/SCTV2-150	142381	0 to 50/100/150A	Average	Pure Sinusoidal		•	0 to 10 VDC
A/SCTV2-250	142380	0 to 100/200/250A	Average	Pure Sinusoidal		•	0 to 10 VDC



PRODUCT SPECIFICATIONS

SENSOR NON-SPECIFIC INFORMATION	
Monitored Current Type:	AC Current
Maximum AC Voltage:	600 VAC
Isolation Voltage:	2200 VAC
Operating Frequency Range:	50 to 600 Hz
Core Style:	Solid-Core and Split-Core Versions available (See Ordering Grid)
Supply Voltage:	Induced from the Monitored Conductor (Insulated Conductors only)
Sensor Amperage Range:	See Ordering Grid (Field Selectable)
Output Signal Number of Wires:	A/CTE2 & A/SCTE2 Series: 0 to 5 VDC A/CTV2 & A/SCTV2 Series: 0 to 10 VDC 2-Wires
Accuracy:	A/CTE2 & A/SCTE2 Series: (0-10A Range Only): +/- 1% from 5-100% of Selected Range A/CTE2 & A/SCTE2 Series: (All Other Ranges): +/- 1% from 2-100% of Selected Range A/CTV2: +/- 1% from 5-100% of Selected Range A/SCTV2 Series: (0 to 10A Range Only): +/- 2% from 5 to 100% of Selected Range A/SCTV2 Series: (All Other Ranges): +/- 1% from 5 to 100% of Selected Range
Response Time:	< 300 mS (Rise and Fall Times)
Aperture Size:	0.75" (19.05 mm)
Din Rail Size:	35 mm (U.S. Patent No. 7,416,421)
Operating Temperature Range:	5 to 104°F (-15 to 40°C)
Operating Humidity Range:	0 to 95%, non-condensing
Recommended Storage Temperature RH Range:	41 to 95°F (5 to 35°C) 40% to 85% RH, non-condensing
Enclosure Material Flammability Rating:	PC/ABS (Polycarbonate/ABS Blend) UL94-V0
Wiring Connections:	2 Position, Screw Terminal Block (Polarity Sensitive)
Wire Recommendations:	2 Conductor (Shielded Cable)
Wire Size:	18 to 24 AWG (0.823 mm to 0.205 mm ²) Copper Wires only
Terminal Block Torque Rating:	4.43 to 5.31 in.-lbs. (0.5 to 0.6 Nm)
Minimum Mounting Distance:	1" (2.6 cm) between current sensor & other magnetic devices (Relays, Contactors, Transformers)

Note 1: All current output sensors are calibrated at an ambient room temperature of 71°F (21.5°C)

WARRANTY

The ACI Voltage Output Sensors are covered by ACI's Five (5) Year Limited Warranty, which is located in the front of ACI'S SENSORS & TRANSMITTERS CATALOG or can be found on ACI's website: www.workaci.com.

W.E.E.E. DIRECTIVE

At the end of their useful life the packaging and product should be disposed of via a suitable recycling centre. Do not dispose of with household waste. Do not burn.



NOTES

NOTES



NOTES

NOTES



